

TURTLE MOUNTAIN SCHOOL DIVISION

PLAN 2009 - 2010

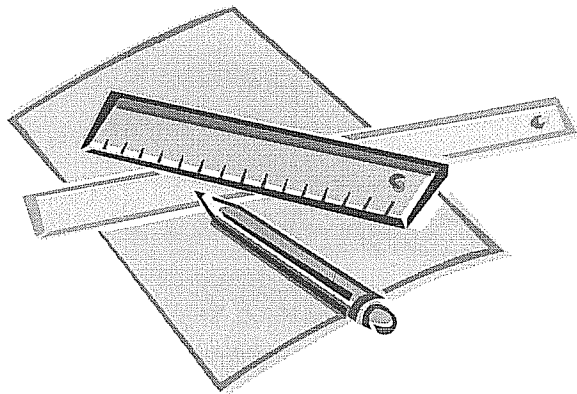

PLANNING AND PRIORITIES

DECEMBER 2008

ACKNOWLEDGEMENTS

Turtle Mountain School Division acknowledges the contribution of many people who have contributed to the development, and on-going improvement, of this divisional action plan. Our main planning session was held on October 18, 2008. This year's planning exercises included trustees, senior administration and school administrators.

Plan 2008-2009 is the result of the input of those who participated in the planning session and the Board's review of the priorities created at that time.

■ Turtle Mountain School Division Board of Trustees:

Rhonda Coupland, Trustee, Ward I
 Gail Patterson, Trustee, Ward I
 Shirley Highfield, Trustee, Ward II
 Brad Heide, Trustee, Ward II
 Gordon Wooley, Trustee, Ward III

Bill Korchinski, Trustee, Ward I
 Darrell Desrosiers, Trustee, Ward II
 Garth Nichol, Vice-Chair, Ward II
 Samantha Cole, Chair, Ward III

■ Turtle Mountain School Division Administration:

Larry Rainnie, Superintendent
 Tanya Edgar, Assistant Superintendent of Student Services

Kathy Siatecki, Secretary-Treasurer

Introduction

As Turtle Mountain School Division Trustees prepared to create our Division action plan in November, 1998, they began by examining their role in promoting public school education and providing effective educational leadership in Turtle Mountain School Division. Collectively, the Board of Trustees identified a set of beliefs that guide how we operate as we make leadership decisions. Since that time, the following beliefs have guided the actions of Turtle Mountain School Division and its senior administration.

1. **We will be accountable for our decisions.**
2. **We will operate in an open and public way.**
3. **We will work as a team and attempt to involve people in decision-making and encourage the taking of responsibility at many levels.**
4. **We will remain open to new ideas, consider and listen to the input of others.**
5. **We value honesty.**
6. **We believe in fiscal responsibility.**

These principles continue to guide the decisions that are made and the way those decisions are communicated. Over the course of next year and beyond, we will be discussing the possibility of change and improvement in the areas identified by our planning group.

Turtle Mountain School Division has committed itself to the concept of planning for continuous improvement. The concept of continuous improvement involves planning, implementing, evaluating and revising the plan and implementing to try to meet certain objectives. Continuous improvement means asking trustees, administrators, staff, parents and other stakeholders, to involve themselves in a collective effort to consider what we do and how we do it and, where possible, to make improvements as we go along to serve the needs of our students.

Planning involves gathering data, from stakeholders throughout Turtle Mountain School Division. Parents and students continue to be surveyed in a variety of ways by the Division and our schools.

This broad-range of feedback helps make organizational planning meaningful and continuous improvement possible.

Division Mission Statement

Turtle Mountain School Division's Mission Statement reads:

“The students are the focus of all our efforts. The Division strives to provide an education that prepares individuals for a meaningful life in a changing world. We promote a learning environment that begins in the home, continues in the school and is supported by the community.”

Our mission statement reflects two important values the Division holds as fundamental. First, **“The students are the focus of all our efforts”**. This requires a commitment by the Board, schools and staff to consider students first. Our mission statement also recognizes that our ultimate goal is to

prepare, “...**individuals for a meaningful life in a changing world**”. This recognizes that change is a constant for both our students and our school division.

The planning session held on October 18, 2008 identified two goals for 2009-2010:

1. All students will develop career awareness skills appropriate to their grade levels.
2. Kindergarten to grade 8 learning outcomes will improve by a minimum of 5% from June 2009 to June 2010.

Both goals identified fall within the priority “We will work to develop students skills to assist them in leading meaningful lives” which is detailed later in the document.

During the planning process, participants discussed internal and external factors that could impact the two goals as well as people that would support the goals and areas we could be better at to help achieve the goals. This information is recorded below:

Internal Factors	External Factors
<p>Strengths:</p> <ul style="list-style-type: none"> * strong educator team * quality of entering students * community schools * committed school board * physical plant and grounds * fiscal house in order * leadership at many levels and areas * creative in providing range of programs * planning strategy * technologically savvy * accountability mentality * embracing change and challenges * student focused -> strong student services * class size * working and learning environment * extra-curricular programs <p>Weaknesses:</p> <ul style="list-style-type: none"> * can't offer full range of programs (with traditional approaches) * shortage of specialists * enrichment 	<p>Opportunities:</p> <ul style="list-style-type: none"> * international students * healthy communities * partnerships with external groups * partnerships with facilities * technology and ICT * technology savvy students * recruiting businesses * immigration * grants * partnerships with other school divisions * schools of choice <p>Threats:</p> <ul style="list-style-type: none"> * declining enrolment * changing world * fewer staff -> fewer coaches * travel costs and distance * increased student needs * funding * staff costs * lower tax base * amalgamation * schools of choice

People to Involve	Areas to Be Better
<ul style="list-style-type: none"> * instructional staff * parents * community * resource people (i.e. P.D.) * students * remaining board members * tax payers * surrounding communities * especially businesses * other school divisions * MECY – especially funding 	<ul style="list-style-type: none"> * communication * integrating student services planning * culling task responsibilities * allocating funding * creative ways of doing things * providing time to do tasks required * P.D.

Turtle Mountain School Division Priorities

Plan 2009-2010 contains the following broad Division priorities that will serve to underpin all of the Board's decisions for the school year. The priorities are in no particular order.

- **We will work to develop students' skills to assist them in leading meaningful lives.**
- **We will promote professional development, for all levels of the organization, that improves the quality of education offered to our students.**
- **We will communicate effectively with our stakeholders.**
- **We will provide safe environments for students and staff within the Division.**

Under each of the Division's priorities, are expected outcomes and
how they will be achieved.

The appendix contains the Division Planning Cycle.

TMSD 2009/2010 PLAN PRIORITIES

A. We will work to develop students' skills to assist them in leading meaningful lives.

EXPECTED OUTCOMES	DIVISION STRATEGIES	INDICATORS	DATA SOURCES
<p>Division students will meet or exceed grade level expectations.</p>	<ul style="list-style-type: none"> ▪ Division initiatives in kindergarten to grade eight assessments will continue with appropriate responses to the results being developed by schools. ▪ Kindergarten to grade eight report cards will be used to report to the Board the number of students at, above or below grade level in each of the subject areas. ▪ Some professional development funding will be available for this. 	<ul style="list-style-type: none"> ▪ Assessments occur. ▪ Reports are created and shared with the Board. 	<ul style="list-style-type: none"> ▪ Assessment reports. ▪ Report cards. ▪ Board minutes.
<p>The Board will support collaboration between schools and teachers (for example grade group meetings, team teaching, buddy system, etc.)</p>	<ul style="list-style-type: none"> ▪ A specific amount of the technology budget will be allocated to computer hardware. ▪ The Division will support professional development sessions for teachers. 	<ul style="list-style-type: none"> ▪ Results reported to schools and the Board. ▪ Professional development funding accessed. 	<ul style="list-style-type: none"> ▪ Assessment data reports to the Board. ▪ Professional development records. Minutes from committee and Board meetings. ▪ Technology budget records. ▪ Professional development records.
<p>The Division will support the implementation of the K-8 Information and Communication Technology Continuum throughout the Division.</p>	<ul style="list-style-type: none"> ▪ The Division will encourage and support a variety of individual and team activities for students including outdoor activities and creative movement such as dance instruction. ▪ The Division will encourage schools to use community resources. ▪ The Division will support wellness opportunities for staff and students. 	<ul style="list-style-type: none"> ▪ Budget allocations made. ▪ Professional development funding accessed. ▪ Outdoor activities being conducted. ▪ Community resources being used. ▪ Staff and students participating in wellness activities. 	<ul style="list-style-type: none"> ▪ School newsletters. ▪ Professional development reports.
<p>The Division will continue to implement the regulations of Bill 13 (appropriate education).</p>	<ul style="list-style-type: none"> ▪ The Division will develop policy regarding Bill 13. 	<ul style="list-style-type: none"> ▪ Meetings held to look at policy development. 	<ul style="list-style-type: none"> ▪ Policy and procedures in the Division Policy and Administration Manuals.
<p>Career Development Plans will be created by all schools.</p>	<ul style="list-style-type: none"> ▪ Career Development Plan resources provided to schools. 	<ul style="list-style-type: none"> ▪ Plans in place and shared with school board. 	<ul style="list-style-type: none"> ▪ School meeting minutes. ▪ Board minutes.

EXPECTED OUTCOMES	DIVISION STRATEGIES	INDICATORS	DATA SOURCES
<p>The Division will provide opportunities for high school students to explore careers.</p>	<ul style="list-style-type: none"> ▪ The Division will continue supporting the Senior Years Apprenticeship Option Program. ▪ The Division will implement the Career and Technology Studies program including staff allocations to Boissevain and Killarney Schools. ▪ 2009-10 Budget will support non-staffing costs for LT's program. 	<ul style="list-style-type: none"> ▪ Meetings held to formulate plan. ▪ Students registered in the Senior Years Apprenticeship Program. ▪ Division and school representatives meeting to discuss the Career and Technologies Studies Program. 	<ul style="list-style-type: none"> ▪ Senior Years Apprenticeship Program Option records/reports. ▪ Minutes of meetings regarding Career and Technology Studies. ▪ Staffing allocations.
<p>K-8 learning outcomes will improve by a minimum of 5% from June 2009 to June 2010.</p>	<ul style="list-style-type: none"> ▪ Outcome discussed by Division committees and school staffs. ▪ Outcome becomes part of school plans. ▪ Outcome is shared with Division Teachers' P.D. Committee. ▪ K-8 Report Cards will be used to gather data. 	<ul style="list-style-type: none"> ▪ Meetings held. ▪ School plans developed. ▪ Tally sheets completed for report card data. ▪ P.D. activities held. 	<ul style="list-style-type: none"> ▪ Meeting minutes ▪ School plans ▪ Tally sheets ▪ Growth plans
<p>The Division will review its assessment practices and policies to find the appropriate balance between assessments of learning and assessment for learning.</p>	<ul style="list-style-type: none"> ▪ Professional development on assessment practises. ▪ Feedback from Division administrators and teacher groups regarding assessment. 	<ul style="list-style-type: none"> ▪ Meetings held. ▪ Professional development occurs. 	<ul style="list-style-type: none"> ▪ Meeting minutes. ▪ Professional development budget records.
<p>Division high school students will receive financial literacy education.</p>	<ul style="list-style-type: none"> ▪ All high school students will complete the consumer mathematics courses for grades 10, 11 and 12 or similar course(s) dealing with financial literacy. 	<ul style="list-style-type: none"> ▪ Courses offered. 	<ul style="list-style-type: none"> ▪ Course enrolments.
<p>All students will develop career awareness skills appropriate to their grade levels by June 2010.</p>	<ul style="list-style-type: none"> ▪ Division Administrators council discuss career awareness progress in 2009-10. ▪ Outcome discussed in school staff meetings. ▪ Outcome becomes part of school plans for 2009-2010. ▪ Outcome is shared with the Teachers' P.D. Committee for P.D. Planning. ▪ Students share career awareness skills during student-led conferences. ▪ Teachers provided P.D. on career awareness. ▪ Division budget provides funds for P.D. 	<ul style="list-style-type: none"> ▪ Meetings held. ▪ School plans developed. ▪ Student-led conferences include career awareness discussions. ▪ P.D. activities held. ▪ Budget reflects P.D. costs. 	<ul style="list-style-type: none"> ▪ Minutes of meeting. ▪ Student portfolios of evidence of career awareness. ▪ Budget documents. ▪ Growth plans.

B. We will promote professional development for all levels of the organization that improves the quality of education offered to our students.

EXPECTED OUTCOMES	DIVISION STRATEGIES	INDICATORS	DATA SOURCES
The K-8 Literacy with ICT Continuum will be promoted throughout the Division.	<ul style="list-style-type: none"> ▪ The Division will support teacher collaboration through professional development funding support. 	<ul style="list-style-type: none"> ▪ Teachers are meeting and collaborating. 	<ul style="list-style-type: none"> ▪ Dates of meetings. ▪ Professional development budget records.
The Division will assess the effectiveness of professional development for staff.	<ul style="list-style-type: none"> ▪ Teachers will report on their professional development activities and the implementation of these activities in their classrooms during Education Specific Meetings. 	<ul style="list-style-type: none"> ▪ Reports are given at Education Specific Meetings. 	<ul style="list-style-type: none"> ▪ Minutes of the Education Specific Meetings.
All employees will have an opportunity for professional development.	<ul style="list-style-type: none"> ▪ Professional development funds available. ▪ Division administration working with employee groups to plan/support professional development activities. 	<ul style="list-style-type: none"> ▪ Employees participating in professional development activities. 	<ul style="list-style-type: none"> ▪ Leave forms. ▪ Budget statements. ▪ Meetings minutes.

C. We will communicate effectively with our stakeholders.

EXPECTED OUTCOMES	DIVISION STRATEGIES	INDICATORS	DATA SOURCES
<p>Division documents will be accessible to our stakeholders.</p>	<ul style="list-style-type: none"> ▪ Various methods of communication will be used (i.e. Division Board Office Staff, Division website, newspaper items, Board Highlights, etc.) 	<ul style="list-style-type: none"> ▪ Materials will be available at the Board Office; documents will be on the web-site; articles will be put in the newspapers; Highlights will be published. 	<ul style="list-style-type: none"> ▪ Records of the documents shared.
<p>Division stakeholders will have an opportunity for effective communication with the Board.</p>	<ul style="list-style-type: none"> ▪ Stakeholders will be involved in the Division's planning process. ▪ Information from stakeholders will be received at focus group meetings, education specific meetings, budget consultation processes, presentations to the Board, etc. ▪ Budget information presentations will be offered to towns, municipalities and chambers of commerce. 	<ul style="list-style-type: none"> ▪ Meetings, presentations and consultations being done. ▪ Presentations held. 	<ul style="list-style-type: none"> ▪ Board meeting minutes.
<p>The Division will work to improve the communications within the organization.</p>	<ul style="list-style-type: none"> ▪ Review Division brochures. ▪ Promote the use of email and the Division website. ▪ Liaison meetings with union groups. ▪ Continue focus group meetings. 	<ul style="list-style-type: none"> ▪ Brochures updated. ▪ Email and website used. ▪ Meetings held. 	<ul style="list-style-type: none"> ▪ Copies of brochures. ▪ Website traffic. ▪ Meeting minutes.

D. We will promote safe environments for students and staff within the Division.

EXPECTED OUTCOMES	DIVISION STRATEGIES	INDICATORS	DATA SOURCES
<p>Staff and students will interact in a respectful and positive manner.</p>	<ul style="list-style-type: none"> ▪ The Division will promote and support positive behaviour initiatives in our schools (i.e. The Four Pillars, Forty Developmental Assets, Lions Quest, etc.) ▪ The Division will support the Standard of Behaviour Committee as it meets to discuss how to improve student behaviour in the Division. 	<ul style="list-style-type: none"> ▪ Positive behaviour activities are being conducted in our schools. ▪ Meetings held. 	<ul style="list-style-type: none"> ▪ School meeting minutes. ▪ Meeting minutes.
<p>The Division will respect the health and safety needs of students and staff.</p>	<ul style="list-style-type: none"> ▪ Staff will receive appropriate training in health needs. ▪ Student health plans are developed. ▪ The Emergency Preparedness Plan and Crisis Plan are in place. ▪ Safety checks of schools will be conducted. ▪ The Little Black Book will be made available to students and parents. ▪ The Division will promote healthy lifestyles (i.e. AFM, D.A.R.E., Child Development Certificate workshop, healthy lifestyles practices, etc.) 	<ul style="list-style-type: none"> ▪ Staff being trained. ▪ Health plans in place. ▪ Division plans relating to health and safety in place. ▪ Students and parents receiving The Little Black Book. ▪ Healthy lifestyle practices being conducted in Division schools. 	<ul style="list-style-type: none"> ▪ Professional development records. ▪ Student health plan records. ▪ Minutes of the Risk Management Committee. ▪ Schedules in schools for activities related to healthy lifestyles promotion.

TURTLE MOUNTAIN SCHOOL DIVISION PLANNING CYCLE

MONTH	CURRENT SCHOOL YEAR	UPCOMING SCHOOL YEAR
September	<ul style="list-style-type: none"> x Final school plans submitted to Superintendent. x School and Division Emergency Plan Review 	
October	<ul style="list-style-type: none"> x Division Annual Financial Report for previous school year. x Division and school plans submitted to Department. x Division Student Services Plan submitted to Department. x Board self-evaluation completed by October 15 every second year. 	<ul style="list-style-type: none"> x Division Planning Sessions leading to final Division Plan.
November		<ul style="list-style-type: none"> x Final Division Plan approved. x Capital D 3-Year Plan approved.
December		<ul style="list-style-type: none"> x Board Budget Priorities
January	<ul style="list-style-type: none"> x Division Plan Status Report 	<ul style="list-style-type: none"> x Public Budget Consultations and Budget Development
February	<ul style="list-style-type: none"> x Division Plan Status Report 	<ul style="list-style-type: none"> x Final Proposed Budget
March		<ul style="list-style-type: none"> x Proposed Budget Highlights to Public
April	<ul style="list-style-type: none"> x Division Plan Status Report 	<ul style="list-style-type: none"> x Budget Approved x Budget submitted to Province
May	<ul style="list-style-type: none"> x Schools' Plans Status Reports 	<ul style="list-style-type: none"> x Schools submit school budgets to Secretary-Treasurer.
June		<ul style="list-style-type: none"> x 5-Year Capital Plan approved and submitted to Department. x Schools submit first draft of school plan to Superintendent.